

## DGPL198P-3

50 Hz @ 1500rpm, 3-phase/  
4-wiring

**198kVA  
PERKINS  
DGPL198P-3**

### A. STANDARDS & CONDITIONS

#### Design Standards

The designs and the productions are in conformity with:

- Conformance Européenne (CE)
- ISO8528-5:2005
- AS 3000-2018
- AS 3010-2017

#### Environmental Operating Conditions

- Installation place: Outdoors or indoors (well ventilated)
- Ambient temperature: -25°C to 50°C. The coolant heater is needed when the temperature is below 5°C
- Humidity: Less than 90%
- Altitude: Below one thousand (1000) meters above sea level

#### Factory Inspection

- Inspection items
- Protection devices working test
- Starting ability in normal temperature
- 50% rated power load moment capability
- Voltage deviation and speed varying: 0%, 25%, 50%, 75%, 100%, 110% Load

#### Painting Process

- Painting process specifications and colors are based on the manufacturer's standard
- The customer could also choose the color which the manufacturer offers

### B. GENERAL FEATURES

- Perkins engine 1106A-70TAG4
- Close coupled to a Leroy Somer alternator LSA46.2M5
- Microprocessor control module PLC-7420
- ABB main circuit breaker: 320A
- Rotate speed governor: Electrical governor
- Excitation System: Self Excited, SHUNT
- A.V.R. Model: R250
- Key switch
- Emergency stop switch
- ATS (automatic transfer switch) receptacle
- Remote run connector
- 1x12V/120AH sealed for life maintenance free battery
- Lockable battery isolator switch
- Powder coated canopy
- 50° C radiator
- Oil pump on the engine
- Steel base frame with forkslots

- Vibration isolators between the engine/alternator and base frame
- Dry type air filter
- Base fuel tank for 24 hours running
- Drain points for fuel tank
- Breather valve for fuel tank
- Operation Manual / Specifications

### C. GENERAL TECHNICAL DATA

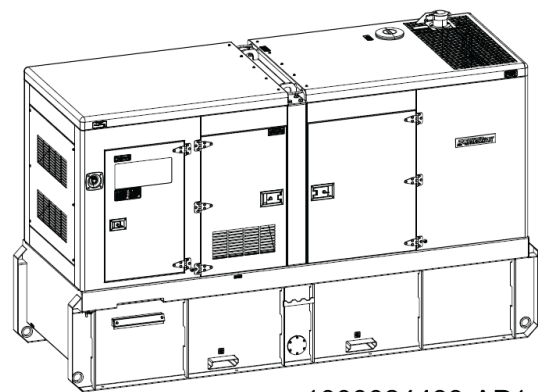

1000024483-AP1-D2

<b>MODEL</b>	DGPL198P-3
<b>STRUCTURE TYPE</b>	R
<b>TANK CAPACITY</b>	1087 L
<b>DRY WEIGHT</b>	2827 kg
<b>NOISE LEVEL @ 7M</b>	74.2 dBA
<b>DIMENSIONS</b>	3468 x 1142x 2088 mm
<b>STANDBY POWER</b>	220 kVA / 176 kW
<b>PRIME POWER</b>	200 kVA / 160 kW
<b>VOLTAGE / AMPERE</b>	415V / 278.2 A

GENSET FUEL CONSUMPTION					
Freq./Load	25%	50%	75%	100%	110%
50Hz (L/h)	N/A	25	36	45.8	49.4

**198kVA**  
**PERKINS**  
**DGPL198P-3**

**POWER SYSTEM**

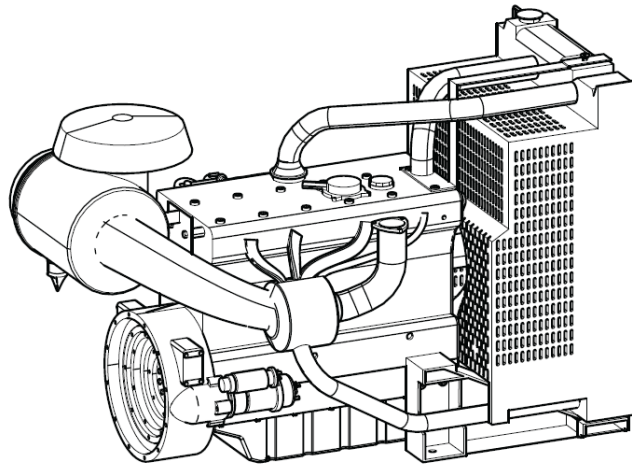

1000152213-AP1-A2

**ENGINE SPECIFICATIO**

1	ENGINE MANUFACTURER/BRAND	Perkins
2	ENGINE MODEL	1106A-E70TAG4
3	DIMENSIONS	1763 × 756 × 1142 mm
4	DRY WEIGHT (APPROX.)	788 kg
5	NUMBER OF CYLINDERS	6
6	BORE	105 mm
7	STROKE	135 mm
8	DISPLACEMENT (LITER)	7.01 L
9	COMPRESSION RATIO	16
10	TYPE OF INJECTION	Direct Injection
11	INTAKE SYSTEM	Turbocharged and air charge cooled
12	INTAKE RESISTANCE	8 kPa
13	COOLING SYSTEM	Water Cooled
14	FAN	Pusher
15	BATTERY VOLTAGE	12V
16	TYPE OF FUEL	ASTM D975, Class 1D & Class 2D
17	TYPE OF OIL	API-CH4/ACEA E5
18	OIL CAPACITY	16.5 L
19	TYPE OF COOLANT	Glycol Mixture
20	COOLANT CAPACITY	21 L
21	BACK PRESSURE	15 kPa
22	STANDBY POWER	176 kW
23	PRIME POWER	160 kW
24	FUEL CONSUMPTION (100% LOAD)	45.8 g/kWh

## DIESEL GENERATION AUSTRALIA

### ALTERNATOR

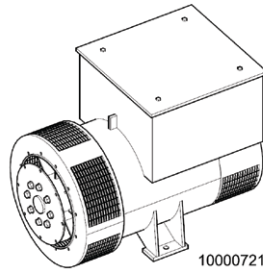

1000072129-AP1-A1

**198kVA**  
**PERKINS**  
**DGPL198P-3**

### ALTERNATOR SPECIFICATIONS

1	ALTERNATOR MANUFACTURER/BRAND	Leroy Somer
2	ALTERNATOR MODEL	LSA46.2M5
3	EXCITER	Brushless
4	COOLING FAN	Cast Alloy Aluminum
5	WINDINGS	100% Copper
6	INSULATION CLASS	H
7	WINDING PITCH	2 / 3
8	TERMINALS	12
9	DRIP PROOF	IP23
10	ALTITUDE	≤ 1000m
11	OVERSPEED	2250rpm
12	AIR FLOW	0.43m³/s(50Hz),0.51m³/s(60Hz)
13	VOLTAGE REGULATION	± 0.5%
14	Total harmonic TGH / THC	at no load < 2.5 % - on load < 2.5%
15	TELEPHONE INTERFERENCE	THF < 2%; TIF <50

### PLC-7420 CONTROL SYSTEM

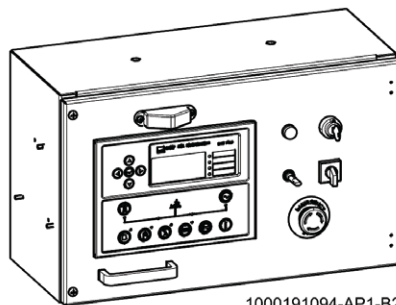

1000191094-AP1-B2

PLC-7420 is an advanced control module based on microprocessor, containing all necessary functions for protection of the genset and the breaker control. It can monitor the mains supply, and automatically start the engine when the mains is abnormal. Accurately measure various operational parameters and display all values and alarms information on the LCD. In addition, the control module can automatically shut down the engine and indicate the engine failure.

- Microprocessor control, with high stability and credibility
- Monitoring and measuring operational parameters of the mains supply and genset
- Indicating operation status, fault conditions, all parameters and alarms
- Multiple protections; multiple parameters display, like pressure, temp. etc.
- Manual, automatic and remote work mode selectable
- Real time clock for time and date display, overall runtime display, 250 log entries
- Overall power output display
- Integral speed/frequency detecting, telling status of start, rated operation, overspeed etc.
- Communication with PC via RS485 OR RS232 interface, using MODBUS protocol

D. OVERALL DIMENSION

**198kVA  
PERKINS  
DGPL198P-3**

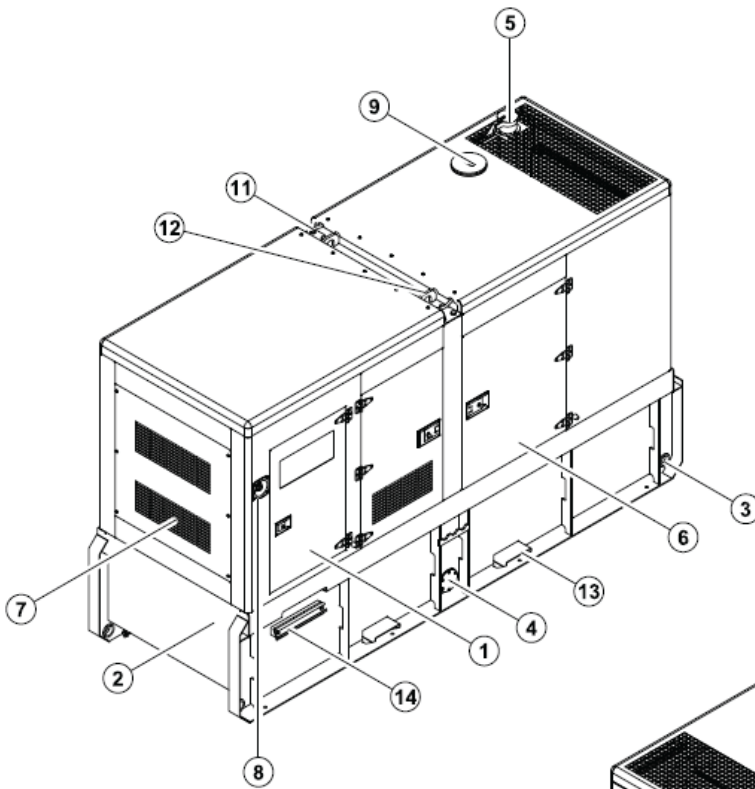

Dry weight	2976kg
Fuel tank capacity	1087L
Dimensions L x W x H	3518x1222x2153mm

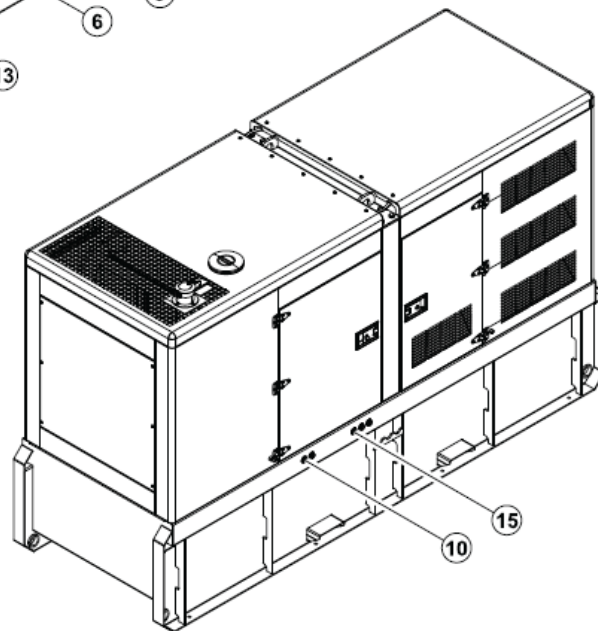

- ⑧ Emergency stop switch
- ⑦ Air inlet
- ⑥ Access door
- ⑤ Exhaust gas outlet
- ④ Fuel drain
- ③ Tie down
- ② Base frame
- ① Control cabinet
- ⑮ Coolant/Oil drain hose fitting
- ⑭ Cable trench
- ⑬ Fork lift channel
- ⑫ Lifting lug
- ⑪ Roping lug
- ⑩ External fuel inlet/return hose fitting
- ⑨ Coolant inlet

<b>DIMENSIONS</b>	3468 x 1142x 2088 mm
<b>DRY WEIGHT</b>	2827 kg

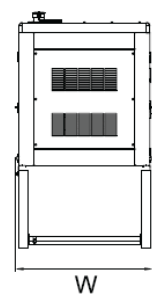
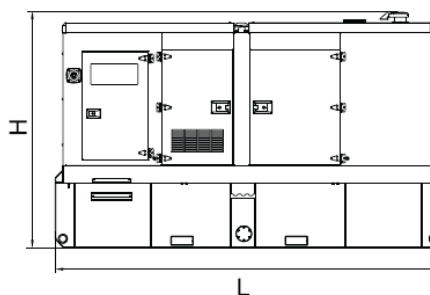

**198kVA  
PERKINS  
DGPL198P-3**

E. CONTROL SYSTEM

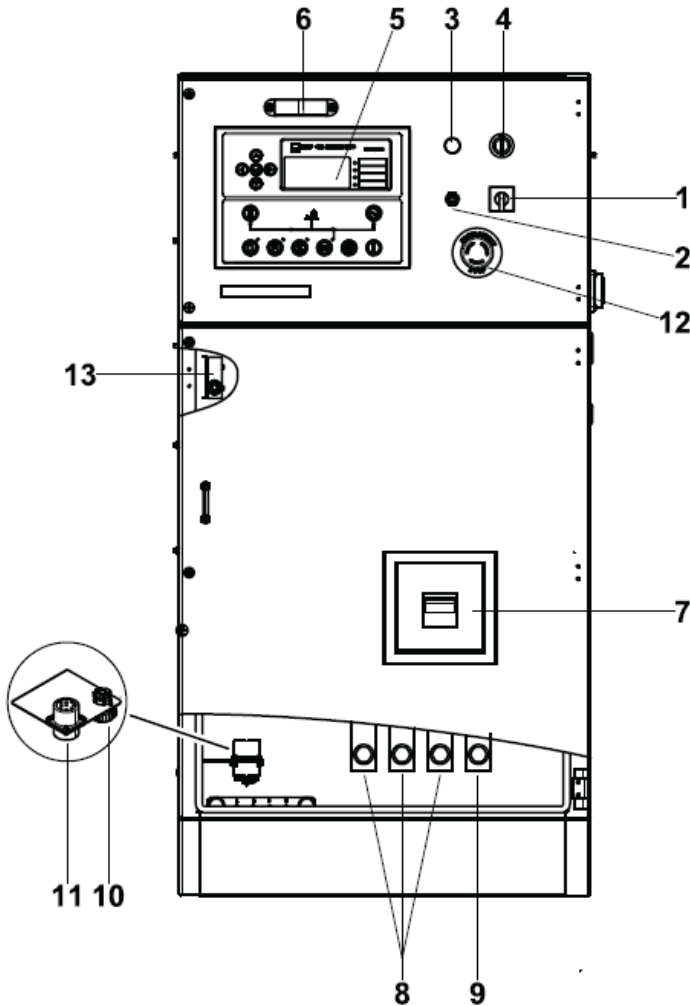

Control & Field wiring cabinet

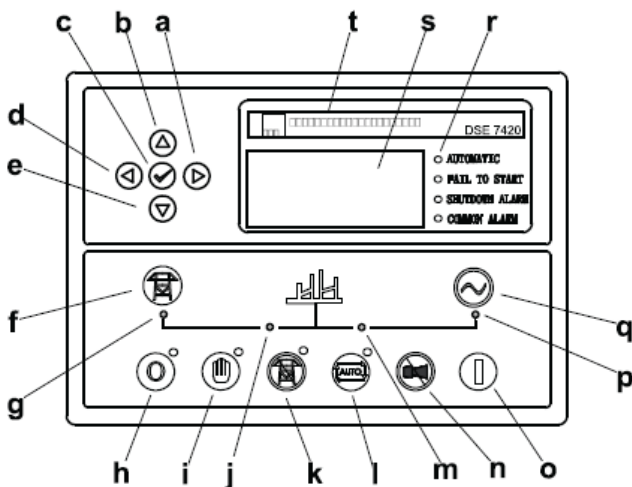

Control module

Ref.	Description
1	Mains Input Changeover Switch
2	Control Cabinet Lamp Switch
3	Charge Indicator
4	Key Switch
5	Control Module
6	Control Cabinet Lamp
7	Main Circuit Breaker
8	Live Wire Terminals
9	Neutral Wire Terminal
10	Mains Input / Remote Control Communication Connector
11	Mains Input / Remote Control / ATS Communication Connector
12	Emergency Stop Switch
13	Limit Switch

a.	Button (next page)
b.	Button (increase value / previous item)
c.	Button (accept)
d.	Button (previous page)
e.	Button (decrease value / next item)
f.	Button (transfer the load to the mains supply, when in Manual)
g.	Mains supply available LED
h.	Stop / Reset Button
i.	Manual button (manual control mode)
j.	Mains supply on load LED
k.	Test button (test mode)
l.	Auto button (auto mode)
m.	Genset on load LED
n.	Mute / Lamp test button
o.	Start button (manual)
p.	Genset available LED
q.	Button (transfer the load to the genset, when in manual mode)
r.	Alarm LED (4 alarm items)
s.	LCD Display
t.	Control Module Name

1000024483-M4-E

10.2020