

## POWER ANYTIME

### GSW-22P (ALT. P)



#### Main Features

Frequency	Hz	50
Voltage	V	400
Power factor	cos $\phi$	0.8
Phase		3

#### Power Rating

Standby power LTP	kVA	21.00
Standby power LTP	kW	16.80
Prime power PRP	kVA	19.32
Prime power PRP	kW	15.46

#### Ratings definition (According to standard ISO8528 1:2005)

##### PRP - Prime Power:

It is defined as being the maximum power which a generating set is capable of delivering continuously whilst supplying a variable electrical load when operated for an unlimited number of hours per year under the agreed operating conditions with the maintenance intervals and procedures being carried out as prescribed by the manufacturer. The permissible average power output over 24 h of operation shall not exceed 70 % of the prime power.

##### LTP - Limited-Time running Power:

It is defined as the maximum power available, under the agreed operating conditions, for which the generating set is capable of delivering for up to 500 h of operation per year (whose no more than 300 for continuative use) with the maintenance intervals and procedures being carried out as prescribed by the manufacturers. No overload capability is available.

## Engine specifications

Engine manufacturer	Perkins	
Model	404D-22G	
[50Hz] Exhaust emission level	Stage IIIA	
Engine cooling system	Water	
Nr. of cylinder and disposition	4 in line	
Displacement	cm <sup>3</sup>	2216
Aspiration	Natural	
Speed governor	Mechanical	
Prime gross power PRP	kW	18.7
Maximum gross power LTP	kW	20.6
Oil capacity	l	10.6
Coolant capacity	l	7
Fuel	Diesel	
Specific fuel consumption @ 75% PRP	g/kWh	238
Specific fuel consumption @ PRP	g/kWh	237
Starting system	Electric	
Starting engine capability	kW	2
Electric circuit	V	12

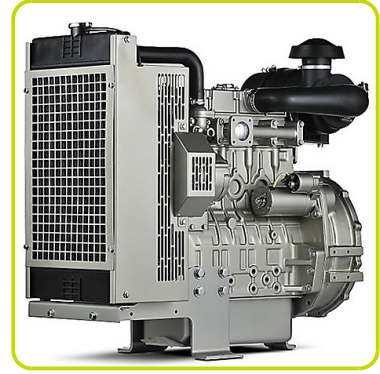

## Engine Equipment

### Standards

The above ratings represent the engine performance capabilities to conditions specified in ISO 8528/1, ISO 3046/1:1986, BS 5514/1

### Fuel system

Rotary type pump

### Lube oil system

Wet steel sump with filler and dipstick

### Filter

- Fuel filter
- Air filter
- Oil filter

### Cooling system

- Mounted radiator
- Thermostatically-controlled system with belt driven coolant pump and pusher fan

## Alternator Specifications

Alternator		Pramac
Model		PB18ES/4
Voltage	V	400
Frequency	Hz	50
Power factor	cos $\phi$	0.8
Poles		4
Standard AVR		AS440
Voltage tolerance	%	1
Efficiency @ 75% load	%	85.6
Class		H
IP protection		22

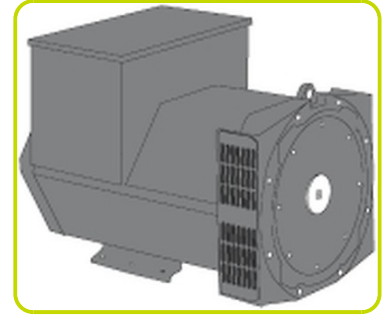

### Mechanical structure

Robust mechanical structure which permits easy access to the connections and components during routine maintenance check-ups.

### Voltage regulator

AVR - STANDARD

With this self excited control system the main stator supplies power via the Automatic Voltage Regulator (AVR) to the exciter stator. The high efficiency semiconductors of the AVR ensure positive build-up from initial low levels of residual voltage.

The exciter rotor output is fed to the main rotor through a three phase full wave bridge rectifier. This rectifier is protected by a surge suppressor against surges caused, for example, by short circuit.

### Windings & Electrical performance

All generator stators are wound to 2/3 pitch. This eliminates triplen (3rd, 9th, 15th ...) harmonics on the voltage waveform and is found to be the optimum design for trouble-free supply of non-linear loads. The 2/3 pitch design avoids excessive neutral currents sometimes seen with higher winding pitches, when in parallel with the mains. A fully connected damper winding reduces oscillations during paralleling. This winding, with the 2/3 pitch and carefully selected pole and tooth designs, ensures very low waveform distortion.

### Insulation / Impregnation

The insulation system is class 'H'.

All wound components are impregnated with materials and processes designed specifically to provide the high build required for static windings and the high mechanical strength required for rotating components.

### Reference standards

Pramac Alternators meet the requirements of BS EN 60034 and the relevant sections of other national and international standards such as BS5000, VDE 0530, NEMA MG1-32, IEC34, CSA C22.2-100, AS1359.

## Genset equipment

### BASE FRAME MADE OF WELDED STEEL PROFILE, COMPLETE WITH:

- Anti-vibration mountings properly sized
- Welded support legs



### PLASTIC FUEL TANK WITH THE FOLLOWING COMPONENT:

- Filler neck
- Air breather (ventilation pipe)
- Minimum fuel level sensor



### OIL DRAINING PIPE WITH CAP:

- Oil draining facilities



### ENGINE COMPLETE WITH:

- Battery
- Liquids (no fuel)

### CANOPY:

- Soundproof canopy made up of modular panels, realized with zincated steel as treatment against corrosion and aggressive conditions, properly fixed and sealed allowing a full weatherproof enclosure.
- Easy access to the genset for maintenance purposes thanks to: Wide lateral access doors fixed by stainless steel hinges and provided with plastic lockable handles and internal perforated galvanized steel-sheet; Detachable panels, with screws holes protected by rubber tap.
- Control panel protection door provided with suitable window and lockable handle.
- Lateral air inlet opening properly protected and soundproofed. Exhaust air outlet from the roof, trough wet section protected by proper grid.
- Single detachable lifting eye placed on the roof.



### SOUNDPROOF:

- Noise attenuation thanks to soundproofing material
- Efficient residential silencer placed inside the canopy



### Dimensional data

Length	(L) mm	1800
Width	(W) mm	850
Height	(H) mm	1260
Dry weight	Kg	715
Fuel tank capacity	l	68



### Autonomy

Fuel consumption @ 75% PRP	l/h	3.92
Fuel consumption @ 100% PRP	l/h	5.28
Running time @ 75% PRP	h	17.35
Running time @ 100% PRP	h	12.88

### Noise level

Guaranteed noise level (LWA)	dB(A)	87
Noise pressure level @ 7 m	dB(A)	58



### Installation data

Exhaust gas flow @ PRP	m <sup>3</sup> /min	3.64
Exhaust gas temperature @ LTP	°C	445

### Electrical Data

Battery capacity	Ah	70
MAX current	A	30.31
Circuit breaker	A	32

### Control panel availability

AUTOMATIC CONTROL PANEL	ACP
-------------------------	-----

## ACP - Automatic control panel

Mounted on the genset, complete with digital control unit AC03 for monitoring, control and protection of the generating set, protected through door with lockable handle

### DIGITAL INSTRUMENTATION (through AC-03)

- Generating set voltage (3 phases)
- Mains voltage
- Generating set frequency
- Generating set current (3 phases)
- Battery voltage
- Power (kVA - kW - kVAr)
- Power factor Cos  $\phi$
- Hours-counter
- Engine speed r.p.m.
- Fuel level (%)
- Engine temperature (depending on model)

### COMMANDS AND OTHERS

- Four operation modes: OFF - Manual starting - Automatic starting - Automatic test
- Pushbutton for forcing Mains contactor or Genset contactor
- Push-buttons: start/stop, fault reset, up/down/page/enter selection
- Remote starting availability
- DC system disconnection switch
- Acoustic alarm
- Automatic battery charger
- RS232 Communication port
- Settable PASSWORD for protection level

### PROTECTIONS WITH ALARM

- Engine protections: low fuel level, low oil pressure, high engine temperature
- Genset protections: under/over voltage, overload, under/over frequency, starting failure, under/over battery voltage

### PROTECTIONS WITH SHUTDOWN

- Engine protections: low fuel level, low oil pressure, high engine temperature
- Genset protection: under/over voltage, overload, under/over battery voltage, battery charger failure
- Circuit breaker protection: III poles
- Earth Fault included in the control unit

### OTHERS PROTECTIONS

- Emergency stop button
- Panel protected through door with lockable handle



### OUT PUT PANEL ACP

Plinth row for connection from ACP to LTS panel.	✓
Power cables connection to Circuit Breaker.	✓



**Supplements:**

To be ordered with the equipment :

---

**ENGINE SUPPLEMENTS**

---

PHS - Coolant Pre-Heating System - available for models: ACP

---

## Accessories

Items available as accessory equipment

---

### LTS - Load Transfer Switch [Accessories for ACP Automatic Control Panel]

Load Transfer Switch panel complete with:

- Change-over switch 4pole made by means of two switch disconnectors mechanically interlocked.
- Emergency stop button

The Load Transfer Switch (LTS) panel operates the power supply changeover between the generator and the Mains in backup applications, guarantying the feeding to the load within a short period of time.

It consists of a standalone cabinet which can be installed separate from the generating set.

The logic control of the power supply changeover is operated by means of the Automatic Control panel mounted on the generating set, so therefore none logic device is required on the LTS panel.

