

## DGPL275C - 3

50 Hz @ 1500rpm, 3-phase / 4-wiring

**275kVA**  
**CUMMINS**  
**DGPL275C - 3**

### A. STANDARDS & CONDITIONS

#### Design Standards

The designs and the productions are in conformity with:

- Conformance Européenne (CE)
- China Compulsory Certification (CCC)
- ISO8528-5:2005
- GB/T2820.5-2009
- AS 3000-1997
- AS 3010.1-1988

#### Environmental Operating Conditions

- Installation place: Outdoors or indoors (well ventilated)
- Ambient temperature: -25°C to 50°C. The coolant heater is needed when the temperature is below 5°C
- Humidity: Less than 90%
- Altitude: Below one thousand (1000) meters above sea level

#### Factory Inspection

- Inspection items
- Protection devices working test
- Starting ability in normal temperature
- 50% rated power load moment capability
- Voltage deviation and speed varying: 0%, 25%, 50%, 75%, 100%, 110% Load

#### Painting Process

- Painting process specifications and colors are based on the manufacturer's standard
- The customer could also choose the color which the manufacturer offers

### B. GENERAL FEATURES

- Cummins engine 6LTAA8.9-G2
- Close coupled to a Stamford alternator UCDI274K
- Microprocessor control module PLC-7420
- NADER main circuit breaker: 400A
- Rotate speed governor: Electrical governor S6700E
- Excitation System: Self Excited, SHUNT
- A.V.R. Model: AS440
- Key switch
- Emergency stop switch
- ATS (automatic transfer switch) receptacle
- Remote run connector
- 2x12V/120AH sealed for life maintenance free battery
- Lockable battery isolator switch
- Powder coated canopy
- 50°C radiator
- Oil pump on the engine
- Non-returning valve for fuel inlet hose of the engine
- Steel base frame with forkslots

- Vibration isolators between the engine/alternator and base frame
- Dry type air filter
- Base fuel tank for 25 hours running
- Drain points for fuel tank
- Breather valve for fuel tank
- Operation Manual / Specifications

### C. GENERAL TECHNICAL DATA

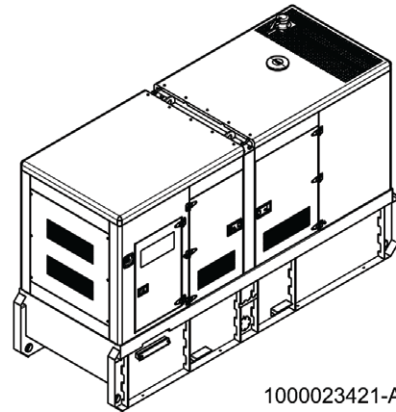

1000023421-AP1-B5

#### MODEL

DGPL275C - 3

#### STRUCTURE TYPE

R

#### TANK CAPACITY

1300 L

#### DRY WEIGHT

3152 kg

#### NOISE LEVEL @ 7M

74.6 dBA

#### DIMENSIONS

3662 x 1322 x 2262 mm

#### STANDBY POWER

275 kVA / 220 kW

#### PRIME POWER

250 kVA / 200 kW

#### VOLTAGE/AMPERE

415 V / 348 A

#### GENSET FUEL CONSUMPTION

Freq./Load	25%	50%	75%	100%	110%
50Hz (L/h)	14.2	25.6	37	50	55.1

## DIESEL GENERATION AUSTRALIA

### DIESEL ENGINE

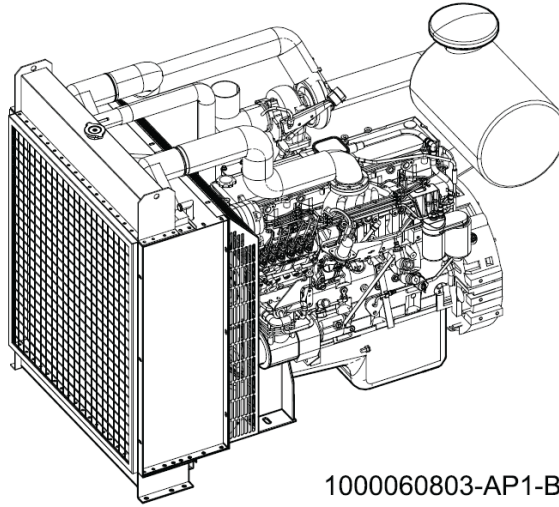

**275kVA**  
**CUMMINS**  
**DGPL275C - 3**

### ENGINE SPECIFICATIONS

1000060803-AP1-B5

1	ENGINE MANUFACTURER/BRAND	Cummins
2	ENGINE MODEL	6LTAA8.9-G2
3	DIMENSIONS	1497.4 x 936.4 x 1228.7 mm
4	DRY WEIGHT (APPROX.)	650 kg
5	NUMBER OF CYLINDERS	6
6	BORE	114 mm
7	STROKE	145 mm
8	DISPLACEMENT (LITER)	8.9 L
9	COMPRESSION RATIO	16.6
10	TYPE OF INJECTION	Direct Injection
11	INTAKE SYSTEM	Turbocharged, water-to-air charge cooled
12	INTAKE RESISTANCE	6.2 kPa
13	COOLING SYSTEM	Water Cooled
14	FAN	Pusher
15	BATTERY VOLTAGE	12/24V
16	TYPE OF FUEL	Diesel
17	TYPE OF OIL	ACEA E2, API CF, CF-4, CG-4
18	OIL CAPACITY	27.6 L
19	TYPE OF COOLANT	Glycol Mixture
20	COOLANT CAPACITY	50.3 L
21	BACK PRESSURE	10.1 kPa
22	STANDBY POWER	240 kW
23	PRIME POWER	220 kW
24	FUEL CONSUMPTION (100% LOAD)	197 g/kWh

## DIESEL GENERATION AUSTRALIA

### ALTERNATOR

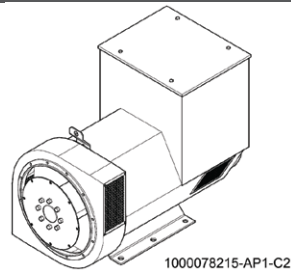

**275kVA**  
**CUMMINS**  
**DGPL275C - 3**

### ALTERNATOR SPECIFICATIONS

1	ALTERNATOR MANUFACTURER/BRAND	Stamford
2	ALTERNATOR MODEL	UCDI274K
3	EXCITER	Brushless
4	COOLING FAN	Cast Alloy Aluminum
5	WINDINGS	100% Copper
6	INSULATION CLASS	H
7	WINDING PITCH	2 / 3
8	TERMINALS	12
9	DRIP PROOF	IP23
10	ALTITUDE	≤ 1000m
11	OVERSPEED	2250rpm
12	AIR FLOW	0.11m³/s(50Hz),0.135m³/s(60Hz)
13	VOLTAGE REGULATION	± 0.5%
14	TOTAL HARMONING TGH / THCat No Load < 1.5%	on load < 5%
15	TELEPHONE INTERFERENCE	THF < 2%; TIF <50

### PLC-7420 CONTROL SYSTEM

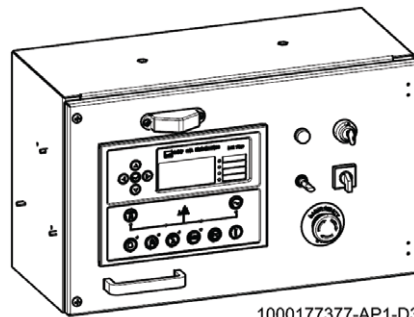

PLC-7420 is an advanced control module based on microprocessor, containing all necessary functions for protection of the genset and the breaker control. It can monitor the mains supply, and automatically start the engine when the mains is abnormal. Accurately measure various operational parameters and display all values and alarms information on the LCD. In addition, the control module can automatically shut down the engine and indicate the engine failure.

- Microprocessor control, with high stability and credibility
- Monitoring and measuring operational parameters of the mains supply and genset
- Indicating operation status, fault conditions, all parameters and alarms
- Multiple protections; multiple parameters display, like pressure, temp. etc.
- Manual, automatic and remote work mode selectable
- Real time clock for time and date display, overall runtime display, 250 log entries
- Overall power output display
- Integral speed/frequency detecting, telling status of start, rated operation, overspeed etc.
- Communication with PC via RS485 OR RS232 interface, using MODBUS protocol

D. OVERALL DIMENSION

**275kVA**  
**CUMMINS**  
**DGPL275C - 3**

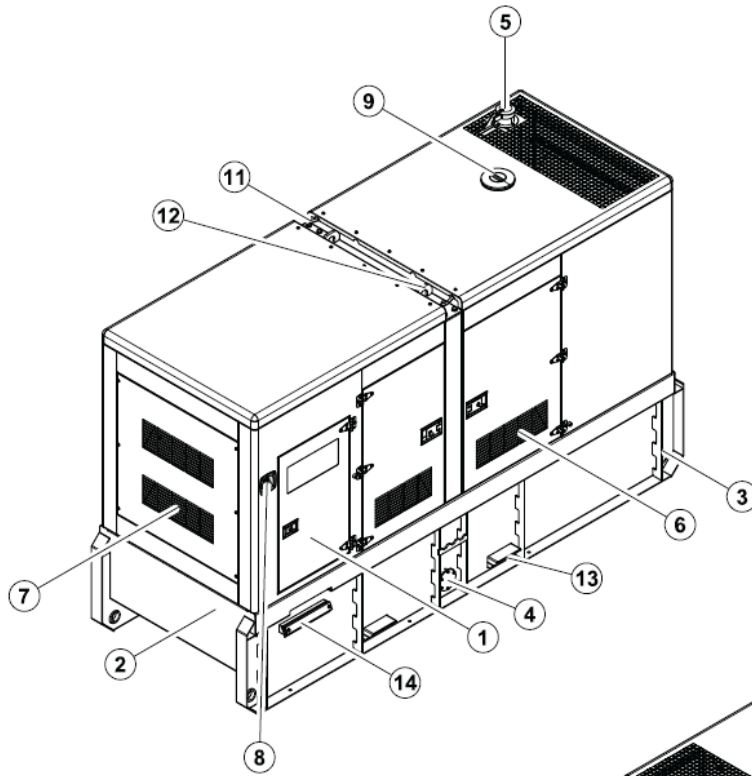

Dry weight	3121kg
Fuel tank capacity	1300L
Dimensions L x W x H	3662x1322x2262mm

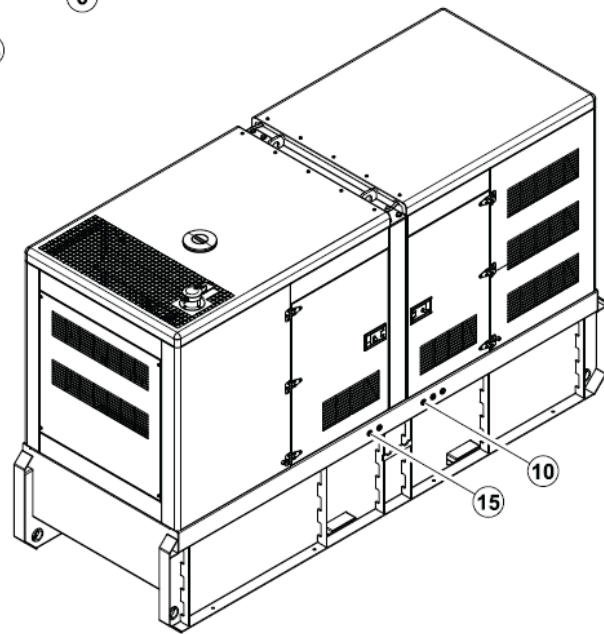

- ⑧ Emergency stop switch
- ⑦ Air inlet
- ⑥ Access door
- ⑤ Exhaust gas outlet
- ④ Fuel drain
- ③ Tie down
- ② Base frame
- ① Control cabinet
- ⑮ Coolant/Oil drain hose fitting
- ⑭ Cable trench
- ⑬ Fork lift channel
- ⑫ Lifting lug
- ⑪ Roping lug
- ⑩ External fuel inlet/return hose fitting
- ⑨ Coolant inlet

<b>DIMENSIONS</b>	3662 x 1322 x 2262 mm
<b>DRY WEIGHT</b>	3152 kg

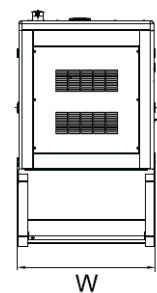
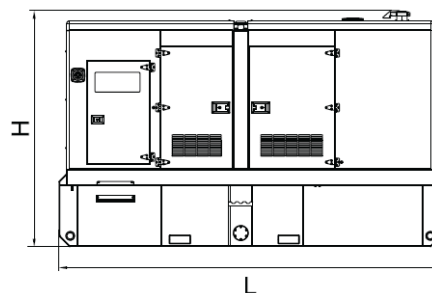

E. CONTROL SYSTEM

**275kVA**  
**CUMMINS**  
**DGPL275C - 3**

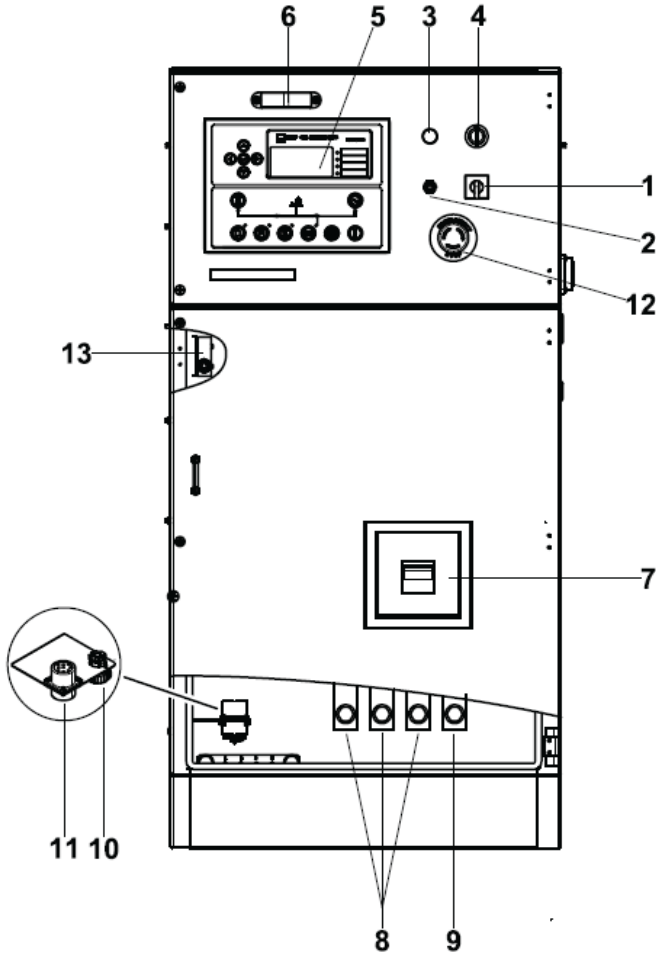

**Control & Field wiring cabinet**

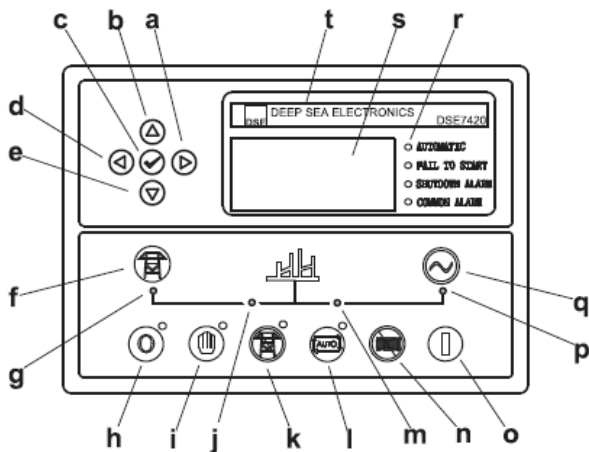

**Control module**

Ref.	Description
1	Mains Input Changeover Switch
2	Control Cabinet Lamp Switch
3	Charge Indicator
4	Key Switch
5	Control Module
6	Control Cabinet Lamp
7	Main Circuit Breaker
8	Live Wire Terminals
9	Neutral Wire Terminal
10	Mains Input / Remote Control Communication Connector
11	Mains Input / Remote Control / ATS Communication Connector
12	Emergency Stop Switch
13	Limit Switch

a.	Button (next page)
b.	Button (increase value / previous item)
c.	Button (accept)
d.	Button (previous page)
e.	Button (decrease value / next item)
f.	Button (transfer the load to the mains supply, when in Manual)
g.	Mains supply available LED
h.	Stop / Reset Button
i.	Manual button (manual control mode)
j.	Mains supply on load LED
k.	Test button (test mode)
l.	Auto button (auto mode)
m.	Genset on load LED
n.	Mute / Lamp test button
o.	Start button (manual)
p.	Genset available LED
q.	Button (transfer the load to the genset, when in manual mode)
r.	Alarm LED (4 alarm items)
s.	LCD Display
t.	Control Module Name

1000023421-E2-E
10.2020