

POWER ANYTIME

DGPL440P-3

50 Hz @ 1500rpm, 3-phase/
4-wiring

440kVA
PERKINS
DGPL440P-3

A. STANDARDS & CONDITIONS

Design Standards

The designs and the productions are in conformity with:

- Conformance Europeenne (CE)
- ISO8528-5:2005
- AS 3000-2018
- AS 3010-2017

Environmental Operating Conditions

- Installation place: Outdoors or indoors (well ventilated)
- Ambient temperature: -25°C to 50°C. The coolant heater is needed when the temperature is below 5°C
- Humidity: Less than 90%
- Altitude: Below one thousand (1000) meters above sea level

Factory Inspection

- Inspection items
- Protection devices working test
- Starting ability in normal temperature
- 50% rated power load moment capability
- Voltage deviation and speed varying: 0%, 25%, 50%, 75%, 100%, 110% Load

Painting Process

- Painting process specifications and colors are based on the manufacturer's standard
- The customer could also choose the color which the manufacturer offers

B. GENERAL FEATURES

- Perkins engine 2206C-E13TAG3
- Close coupled to a Leroy Somer alternator LSA47.2VS4
- Microprocessor control module PLC-7420
- ABB main circuit breaker: 630A
- Rotate speed governor: Electronic fuel injection governor
- Excitation System: Self Excited
- A.V.R.Model: R250
- Key switch
- Emergency stop switch
- ATS (automatic transfer switch) receptacle
- Remote run connector
- 2x12V/120AH sealed for life maintenance free battery
- Lockable battery isolator switch
- Powder coated canopy
- 50° C radiator
- Oil pump on the engine
- Steel base frame with forkslots

- Vibration isolators between the engine/alternator and base frame
- Dry type air filter
- Base fuel tank for 19 hours running
- Drain points for fuel tank
- Breather valve for fuel tank
- Operation Manual / Specifications

C. GENERAL TECHNICAL DATA

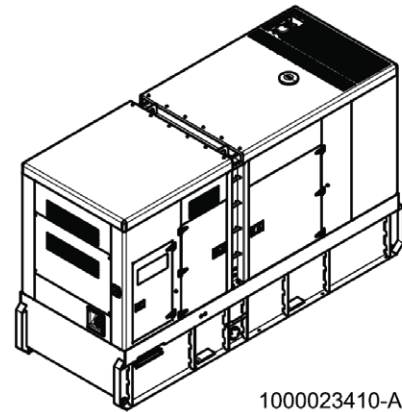

1000023410-AP1-B5

MODEL	DGPL440P-3
STRUCTURE TYPE	R
TANK CAPACITY	1650 L
DRY WEIGHT	4785 kg
NOISE LEVEL @ 7M	72.3 dBA
DIMENSIONS	4242 × 1614 × 2476 mm
STANDBY POWER	430 kVA / 344 kW
PRIME POWER	400 kVA / 320 kW
VOLTAGE / AMPERE	415 V / 556 A

GENSET FUEL CONSUMPTION					
Freq./Load	25%	50%	75%	100%	110%
50Hz (L/h)	N/A	46	65	85	93

DIESEL ENGINE

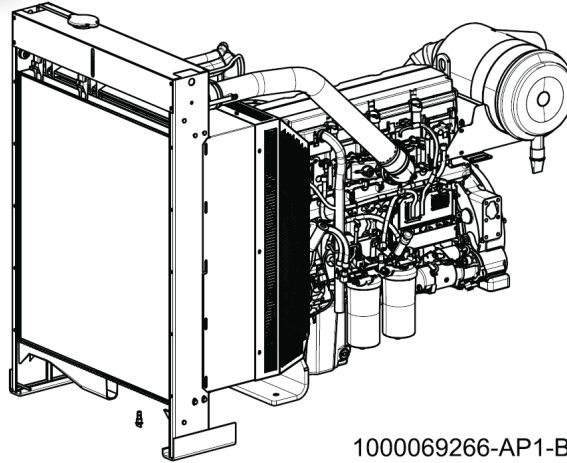

1000069266-AP1-B3

440kVA
PERKINS
DGPL440P-3

ENGINE SPECIFICATIONS

1	ENGINE MANUFACTURER/BRAND	Perkins
2	ENGINE MODEL	2206C-E13TAG3
3	DIMENSIONS	2410 × 1120 × 1725 mm
4	DRY WEIGHT (APPROX.)	1478 kg
5	NUMBER OF CYLINDERS	6
6	BORE	130 mm
7	STROKE	157 mm
8	DISPLACEMENT (LITER)	12.5 L
9	COMPRESSION RATIO	16.3
10	TYPE OF INJECTION	Direct Injection
11	INTAKE SYSTEM	Turbocharged, air-to-air charge cooled
12	INTAKE RESISTANCE	6.4 kPa
13	COOLING SYSTEM	Water Cooled
14	FAN	Pusher
15	BATTERY VOLTAGE	24V
16	TYPE OF FUEL	BSEN590 or ASTM D975 Class 1D and 2D
17	TYPE OF OIL	15W40 to API CI4
18	OIL CAPACITY	40 L
19	TYPE OF COOLANT	Glycol Mixture
20	COOLANT CAPACITY	51.4 L
21	BACK PRESSURE	N/A
22	STANDBY POWER	413 kW
23	PRIME POWER	368 kW
24	FUEL CONSUMPTION (100% LOAD)	85 L/h

**440kVA
PERKINS
DGPL440P-3**

ALTERNATOR

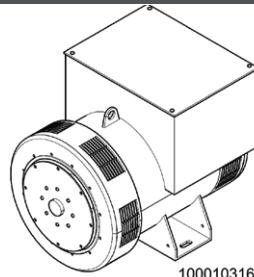

1000103169-AP1-A1

ALTERNATOR SPECIFICATIONS

1	ALTERNATOR MANUFACTURER/BRAND	Leroy Somer
2	ALTERNATOR MODEL	LSA47.2S4
3	EXCITER	Brushless
4	COOLING FAN	Cast Alloy Aluminum
5	WINDINGS	100% Copper
6	INSULATION CLASS	H
7	WINDING PITCH	2 / 3
8	TERMINALS	12
9	DRIP PROOF	IP23
10	ALTITUDE	≤ 1000m
11	OVERSPEED	2250rpm
12	AIR FLOW	0.9m³/s[50Hz], 1.1m³/s[60Hz]
13	VOLTAGE REGULATION	± 0.5%
14	Total harmonic TGH / THC	at no load < 2% - on load < 2%
15	TELEPHONE INTERFERENCE	THF < 2%; TIF < 50

PLC-7420 CONTROL SYSTEM

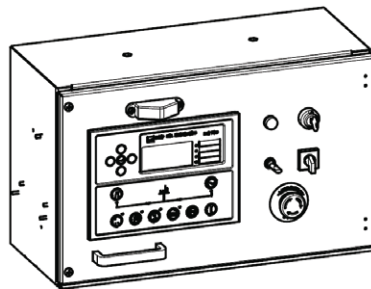

1000191019-AP1-B2

PLC-7420 is an advanced control module based on microprocessor, containing all necessary functions for protection of the genset and the breaker control. It can monitor the mains supply, and automatically start the engine when the mains is abnormal. Accurately measure various operational parameters and display all values and alarms information on the LCD. In addition, the control module can automatically shut down the engine and indicate the engine failure.

- Microprocessor control, with high stability and credibility
- Monitoring and measuring operational parameters of the mains supply and genset
- Indicating operation status, fault conditions, all parameters and alarms
- Multiple protections; multiple parameters display, like pressure, temp. etc.
- Manual, automatic and remote work mode selectable
- Real time clock for time and date display, overall runtime display, 250 log entries
- Overall power output display
- Integral speed/frequency detecting, telling status of start, rated operation, overspeed etc.
- Communication with PC via RS485 OR RS232 interface, using MODBUS protocol

440kVA PERKINS DGPL440P-3

D. OVERALL DIMENSION

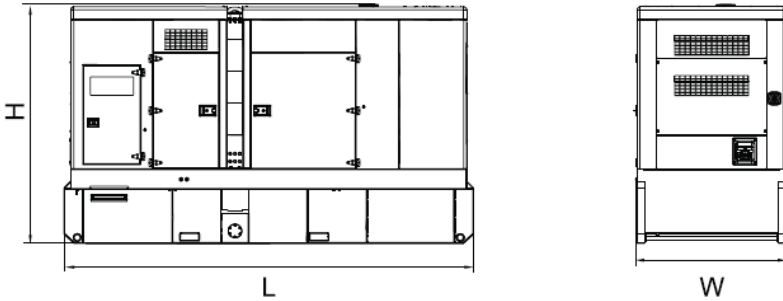

Dry weight	4789kg
Fuel tank capacity	1650L
Dimensions L x W x H	4242x1570x2471mm

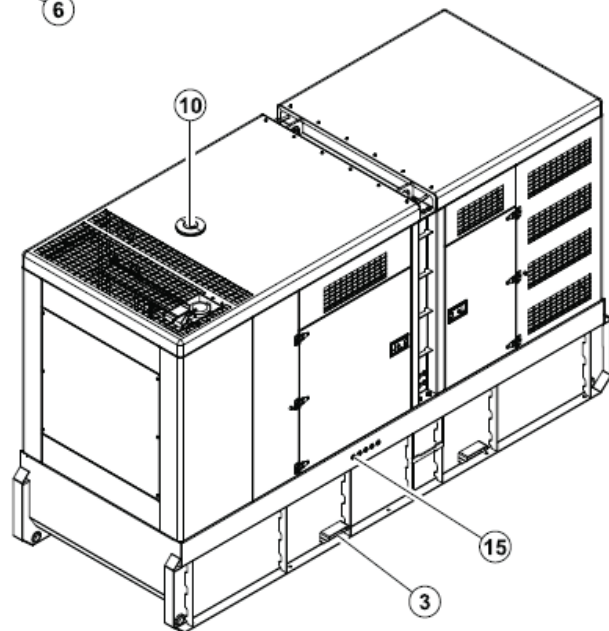
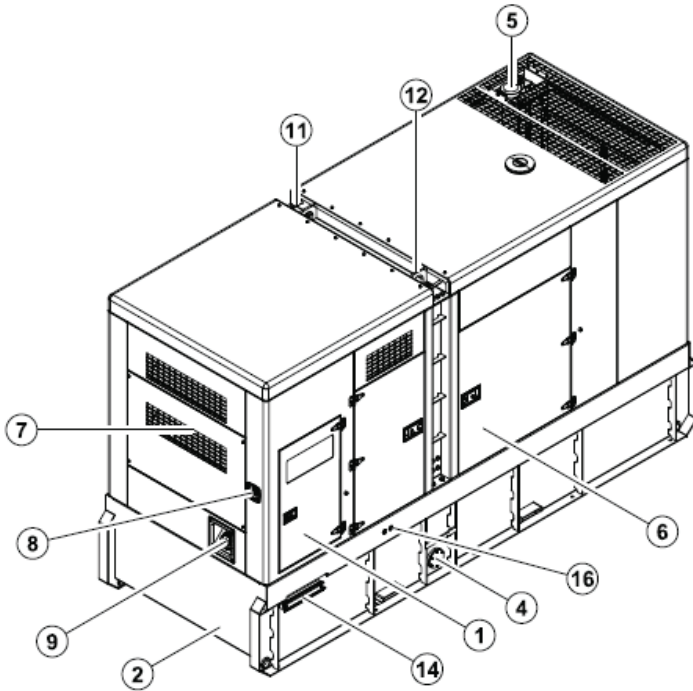

- ⑧ Emergency stop switch
- ⑦ Air inlet
- ⑥ Access door
- ⑤ Exhaust gas outlet
- ④ Fuel drain
- ③ Tie down
- ② Base frame
- ① Control cabinet
- ⑩ Coolant inlet
- ⑨ Fuel inlet
- ⑬ Fork lift channel
- ⑫ Lifting lug
- ⑪ Roping lug
- ⑭ Cable trench
- ⑮ Coolant/Oil drain hose fitting
- ⑯ External fuel inlet/return hose fitting
- ⑰ Access door

DIMENSIONS	4242 × 1614 × 2476 mm
DRY WEIGHT	4785 kg

**440kVA
PERKINS
DGPL440P-3**

E. CONTROL SYSTEM

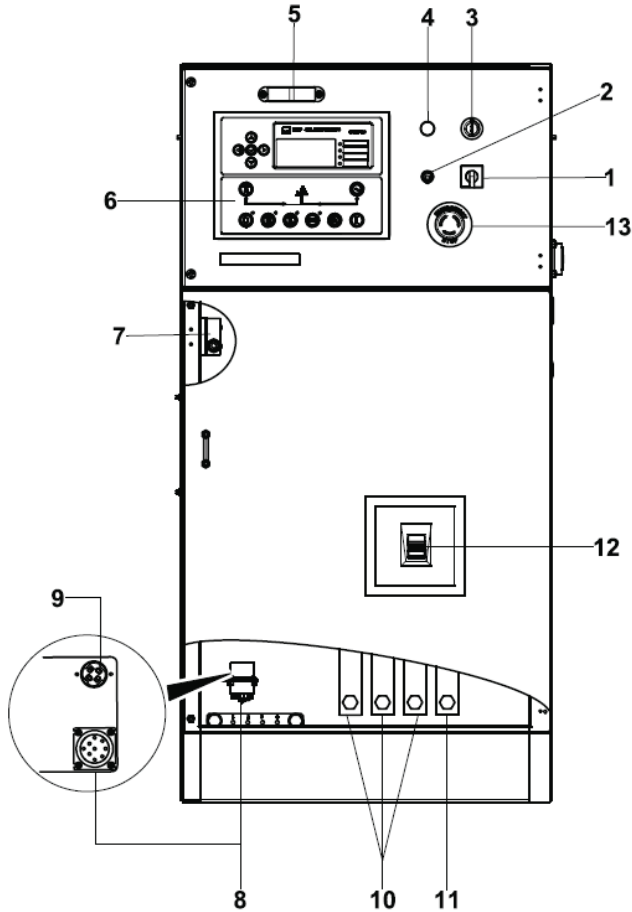

Control & Field wiring cabinet

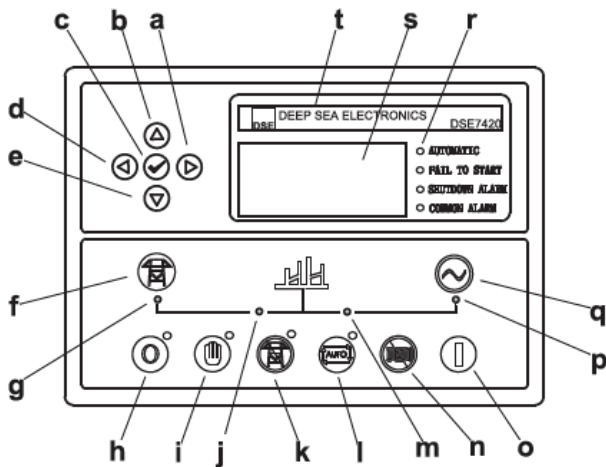

Control module

Ref.	Description
1	Control Cabinet Lamp Switch
2	Mains Input Changeover Switch
3	Charge Indicator
4	Key Switch
5	Control Cabinet Lamp
6	Control Module
7	Limit Switch
8	Mains Input / AMF Communication Connector
9	Mains Input / Remote Communication Connector
10	Live Wire Terminals
11	Neutral Wire Terminal
12	Main Circuit Breaker
13	Emergency Stop Switch

a.	Button (next page)
b.	Button (increase value / previous item)
c.	Button (accept)
d.	Button (previous page)
e.	Button (decrease value / next item)
f.	Button (transfer the load to the mains supply, when in Manual)
g.	Mains supply available LED
h.	Stop / Reset Button
i.	Manual button (manual control mode)
j.	Mains supply on load LED
k.	Test button (test mode)
l.	Auto button (auto mode)
m.	Genset on load LED
n.	Mute / Lamp test button
o.	Start button (manual)
p.	Genset available LED
q.	Button (transfer the load to the genset, when in manual mode)
r.	Alarm LED (4 alarm items)
s.	LCD Display
t.	Control Module Name

1000023411-F4-E

10.2020