

## DGPO7K-3

50 Hz @ 1500rpm, 3-phase/5-wiring

**7kVA**  
**KUBOTA**  
DGPO7K-3

### 1 Standards & Conditions

#### Design Standards

The designs and the productions are in conformity with:

- Conformance Européenne (CE)
- ISO8528-5:2005
- AS 3000-2018
- AS 3010-2017

#### Environmental Operating Conditions

- Installation place: Outdoors or indoors (well ventilated).
- Ambient temperature: -25°C to 50°C. The coolant heater is needed when the temperature is below 5°C
- Humidity: Less than 90%.
- Altitude: Below one thousand (1000) meters above sea level.

#### Factory Inspection

- Inspection items.
- Protection devices working test.
- Starting ability in normal temperature.
- 50% rated power load moment capability.
- Voltage deviation and speed variation: 0%, 25%, 50%, 75%, 100%, 110% Load.

#### Painting Process

- Painting process specifications and colors are based on the manufacturer's standard.
- The customer could also choose the color which the manufacturer offers.

### 2 General Features

- Kubota engine D905-BG
- Close coupled to LSA alternator LSA40VS0
- Microprocessor control module PLC-920
- SCHNEIDER main circuit breaker: 16A
- Rotate speed governor: Mechanical governor
- Excitation system: Self excited, SHUNT
- A.V.R model: R220
- Key switch
- Emergency stop switch
- ATS (automatic transfer switch) receptacle

- Remote run connector
- 1x12V/60AH sealed for life maintenance free battery
- Lockable battery isolator switch
- Powder coated canopy
- 50°C radiator
- Steel base frame
- Vibration isolators between the engine/alternator and base frame
- Dry type air filter
- Base fuel tank for 50 hours running
- Drain points for fuel tank
- Operation Manual / Specifications

### 3 Equipment

#### General technical data

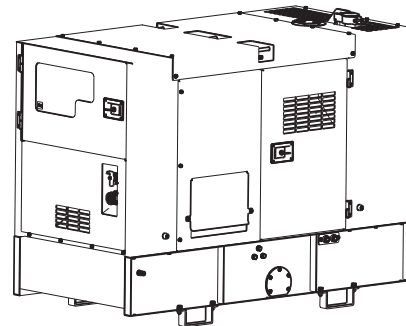

Model..... QSV7KS-AU  
 Tank capacity..... 80L  
 Dry weight..... 560kg  
 Sound pressure level @ 7m ..... 59.0dBA  
 Dimensions L×W×H..... 1450x640x950mm  
 Standby Power ..... 7.5kVA/6kW  
 Prime Power..... 6.6kVA/5.3kW

Voltage	380V	400V	415V	440V	
Ampere	10.0A	9.53A	9.18A	8.66A	
Genset Fuel Consumption					
Frequency/Load	25%	50%	75%	100%	110%
50Hz (L/h)	N/A	1.1	1.6	2.1	2.3

## DGPO7K-3

50 Hz @ 1500rpm, 3-phase/5-wiring

**7kVA**  
**KUBOTA**  
**DGP07K-3**

### Diesel engine

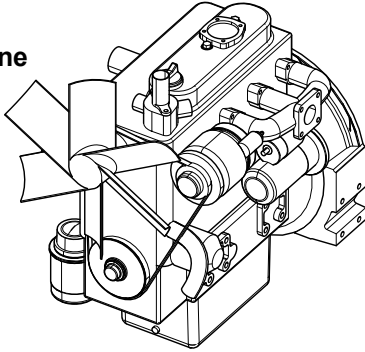

Engine Manufacturer/Brand.....	KUBOTA
Engine Model.....	D905-BG
Dimensions L×W×H.....	551×395×605mm
Dry Weigh (approx.) .....	93Kg
Number of Cylinders.....	3
Bore .....	72mm
Stroke .....	73.6mm
Displacement.....	0.898L
Compression Ratio .....	23
Type of injection.....	Direct injection
Intake System.....	Natural aspirated
Intake Resistance .....	≤1.96kPa
Cooling System .....	Water cooled
Fan .....	Pusher
Battery Voltage .....	12V
Type of Fuel.....	No.2-D (ASTMD975)
Type of Oil .....	APICD
Oil Capacity .....	5.1L
Type of Coolant .....	Glycol mixture
Coolant Capacity .....	N/A
Back Pressure .....	≤7.07kPa
Standby Power .....	7.4kW
Prime Power .....	6.6kW
Fuel Consumption(100%load).....	2.1L/h

### Alternator

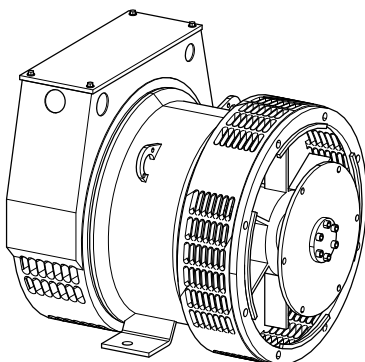

Alternator Manufacturer/Brand .....	Leroy Somer
Alternator Model .....	LSA40VS0
Exciter.....	Brushless
Cooling Fan .....	Cast alloy aluminum
Windings.....	100% copper
Insulation Class .....	H
Winding Pitch.....	2/3
Terminals .....	12
Drip Proof .....	IP23
Altitude.....	≤1000m
Overspeed .....	2250rpm
Air Flow.....	N/A
Voltage Regulation .....	±1.0%
Total Harmonic TGH / THCat no load < 1.5 % - on load < 5%	
Telephone Interference.....	THF<2%;TIF<50

### PLC-920 Control System

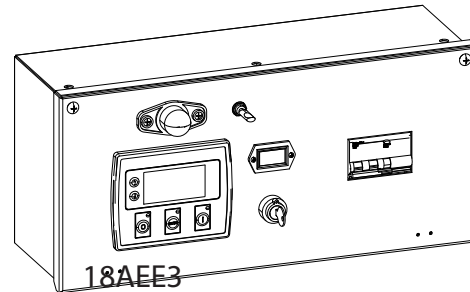

PLC-920 is an advanced control module based on microprocessor designed to control the engine via push buttons on the front panel. The module is used to start and stop the engine and indicate fault conditions, automatically shutting down the engine and giving a true first up fault condition of an engine failure.

#### Standard Control Function

- Manual Engine Control Module
- Low Oil Pressure
- High Engine Temperature
- Auxiliary Shutdown
- Overspeed Protection
- Protection hold-off timer
- Charge Failure warning

## DGPO7K-3

50 Hz @ 1500rpm, 3-phase/5-wiring

**7kVA**  
**KUBOTA**  
DGPO7K-3

### 4 Overall Dimensions

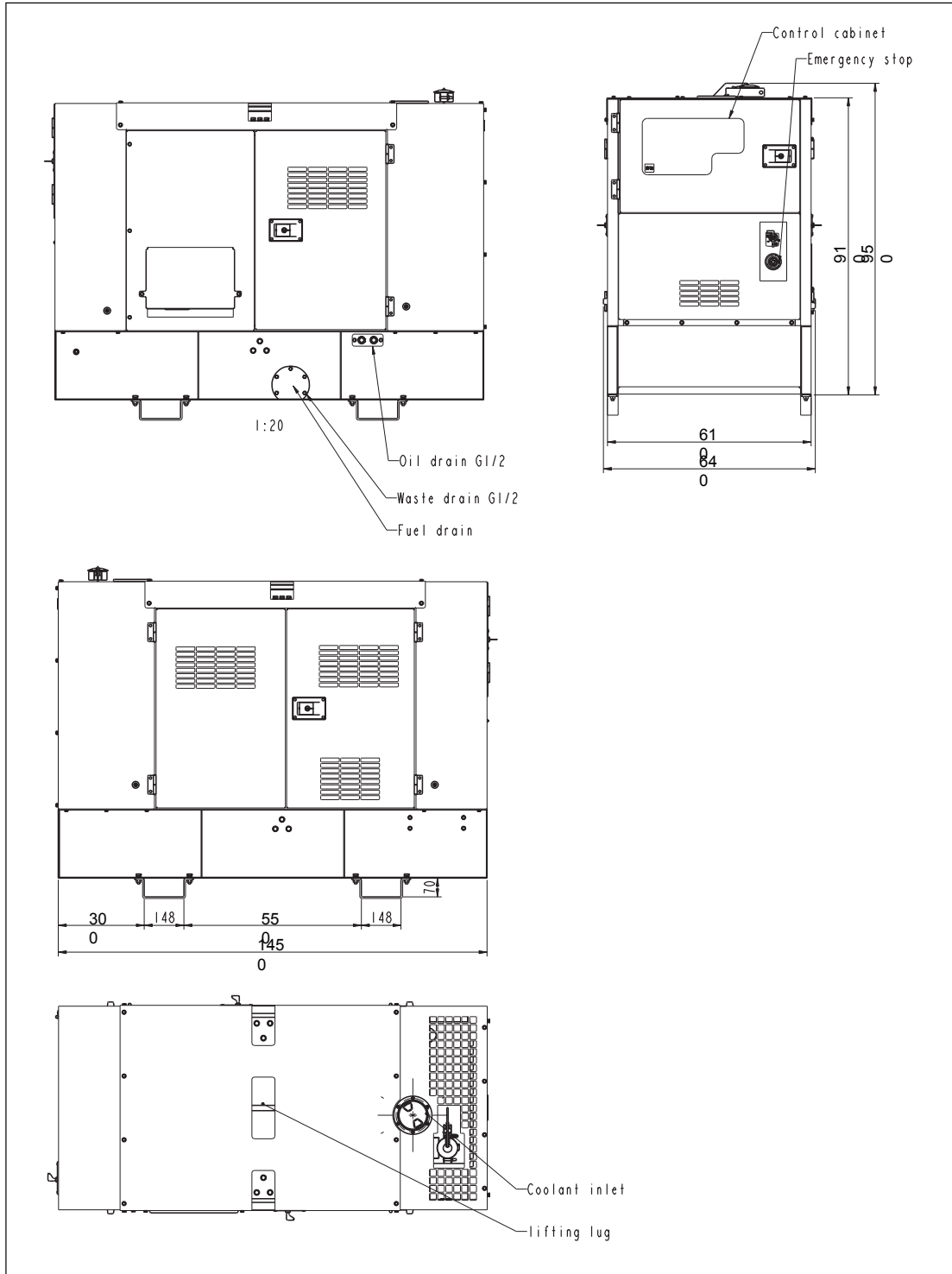

## DGPO7K-3

50 Hz @ 1500rpm, 3-phase/5-wiring

**7kVA**  
**KUBOTA**  
DGPO7K-3

### 5 Control System

