

# DGPL11K-1

## 50Hz @ 1500rpm, 1-Phase / 3-wiring

### A. STANDARDS & CONDITIONS

#### Design Standards

The designs and the productions are in conformity with:

- Conformance Europeenne (CE)
- ISO8528-5: 2005
- GB/T2820.5-2009
- AS 3000-2018
- AS 3010-2017

#### Environmental Operating Conditions

- Installation place: Outdoors or indoors (well ventilated)
- Ambient temperature: -25°C to 50°C. The coolant heater is needed when the temperature is below 5°C
- Humidity: Less than 90%
- Altitude: Below one thousand (1000) meters above sea level

#### Factory Inspection

- Inspection items
- Protection devices working test
- Starting ability in normal temperature
- 50% rated power load moment capability
- Voltage deviation and speed varying: 0%, 25%, 50%, 75%, 100%, 110% Load

#### Painting Process

- Painting process specifications and colors are based on the manufacturer's standard
- The customer could also choose the color which the manufacturer offers

### B. GENERAL FEATURES

- Kubota Engine D1105-BG
- Close coupled to Stamford alternator PI044H
- Microprocessor control module PLC-920
- SCHNEIDER main circuit breaker: 63A
- Rotate speed governor: Mechanical governor
- Excitation System: Self Excited
- A.V.R., Key Switch, Emergency Stop Switch
- Automatic Transfer Switch
- Convenience Receptacles: 1P
- 1x12V/72AH sealed for life maintenance free battery
- Lockable battery isolator switch
- Powder coated canopy
- 50°C radiator
- Oil pump on the engine
- Steel base frame with forklots

- Vibration isolators between the engine/alternator and base frame
- Dry type air filter
- Base fuel tank for 28 hours running
- Drain points for fuel tank
- Operation Manual / Specifications

### C. GENERAL TECHNICAL DATA

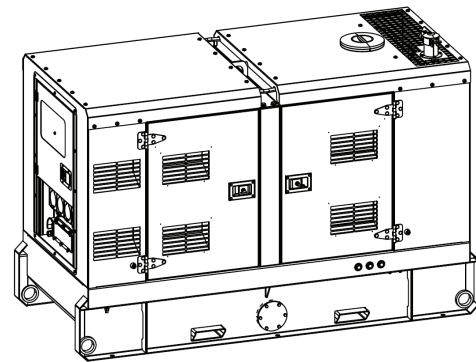

<b>MODEL</b>	PK10S-AU
<b>STRUCTURE TYPE</b>	RS
<b>TANK CAPACITY</b>	100 L
<b>DRY WEIGHT</b>	691 KG
<b>NOISE LEVEL @ 7M</b>	66.6dBA
<b>DIMENSIONS</b>	1932 x 927.5 x 1308mm
<b>STANDBY POWER</b>	11kVA / 8.8kW
<b>PRIME POWER</b>	10kVA / 8kW

Voltage	220V	230V	240V		
Ampere	44.5A	43.5A	41.7A		
GENSET FUEL CONSUMPTION					
Freq./Load	25%	50%	75%	100%	110%
50Hz (L/h)	N/A	1.8	2.9	3.5	3.9

**DIESEL ENGINE**

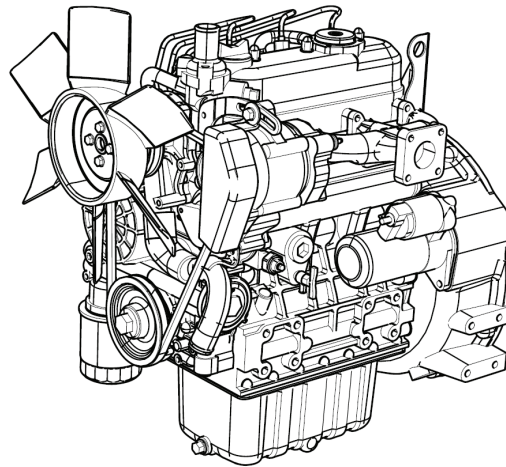

**ENGINE SPECIFICATIONS**

1	ENGINE MANUFACTURER/BRAND	Kubota
2	ENGINE MODEL	D1105-BG
3	DIMENSIONS	549.3 × 398.0 × 604.7 mm
4	DRY WEIGHT (APPROX.)	93kg
5	NUMBER OF CYLINDERS	3
6	BORE	78 mm
7	STROKE	78.4 mm
8	DISPLACEMENT (LITER)	1.123 L
9	COMPRESSION RATIO	22
10	TYPE OF INJECTION	Direct Injection
11	INTAKE SYSTEM	Natural Aspirated
12	INTAKE RESISTANCE	1.96 kPa
13	COOLING SYSTEM	Water Cooled
14	FAN	Pusher
15	BATTERY VOLTAGE	12V
16	TYPE OF FUEL	No.2-D (ASTMD975)
17	TYPE OF OIL	Better than APICD Class
18	OIL CAPACITY	5.1L
19	TYPE OF COOLANT	Glycol Mixture
20	COOLANT CAPACITY	6.4 L
21	BACK PRESSURE	7.07 kPa
22	STANDBY POWER	9.5 kW
23	PRIME POWER	8.4 kW
24	FUEL CONSUMPTION (100% LOAD)	3.5 L/h

## DIESEL GENERATION AUSTRALIA

### ALTERNATOR

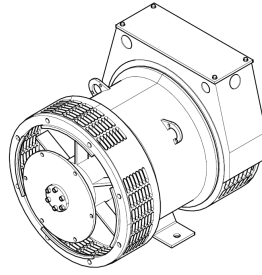

### ALTERNATOR SPECIFICATIONS

1	ALTERNATOR MANUFACTURER/BRAND	Stamford
2	ALTERNATOR MODEL	PI044H
3	EXCITER	Brushless
4	COOLING FAN	Synthetic Plastic
5	WINDINGS	100% Copper
6	INSULATION CLASS	H
7	WINDING PITCH	2 / 3
8	TERMINALS	12
9	DRIP PROOF	IP23
10	ALTITUDE	≤ 1000m
11	OVERSPEED	2250rpm
12	AIR FLOW	0.11m³/s(50Hz),0.135m³/s(60Hz)
13	VOLTAGE REGULATION	± 0.5%
14	TOTAL HARMONIC TGH / THCat No Load < 1.5%	on load < 5%
15	TELEPHONE INTERFERENCE	THF < 2%; TIF <50

### PLC-920 CONTROL SYSTEM

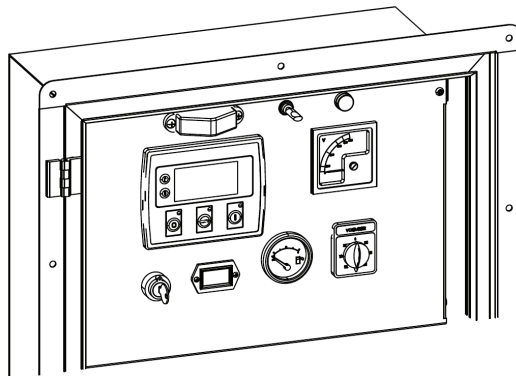

PLC-920 is an advanced control module based on microprocessor designed to control the engine via push buttons on the front panel. The module is used to start and stop the engine and indicate fault conditions, automatically shutting down the engine and giving a true first up fault condition of an engine failure.

#### Standard Control Function

- Manual Engine Control Module
- Low Oil Pressure
- High Engine Temperature
- Auxiliary Shutdown
- Overspeed Protection
- Protection Hold-Off Timer
- Charge Failure Warning

**D. OVERALL DIMENSION**

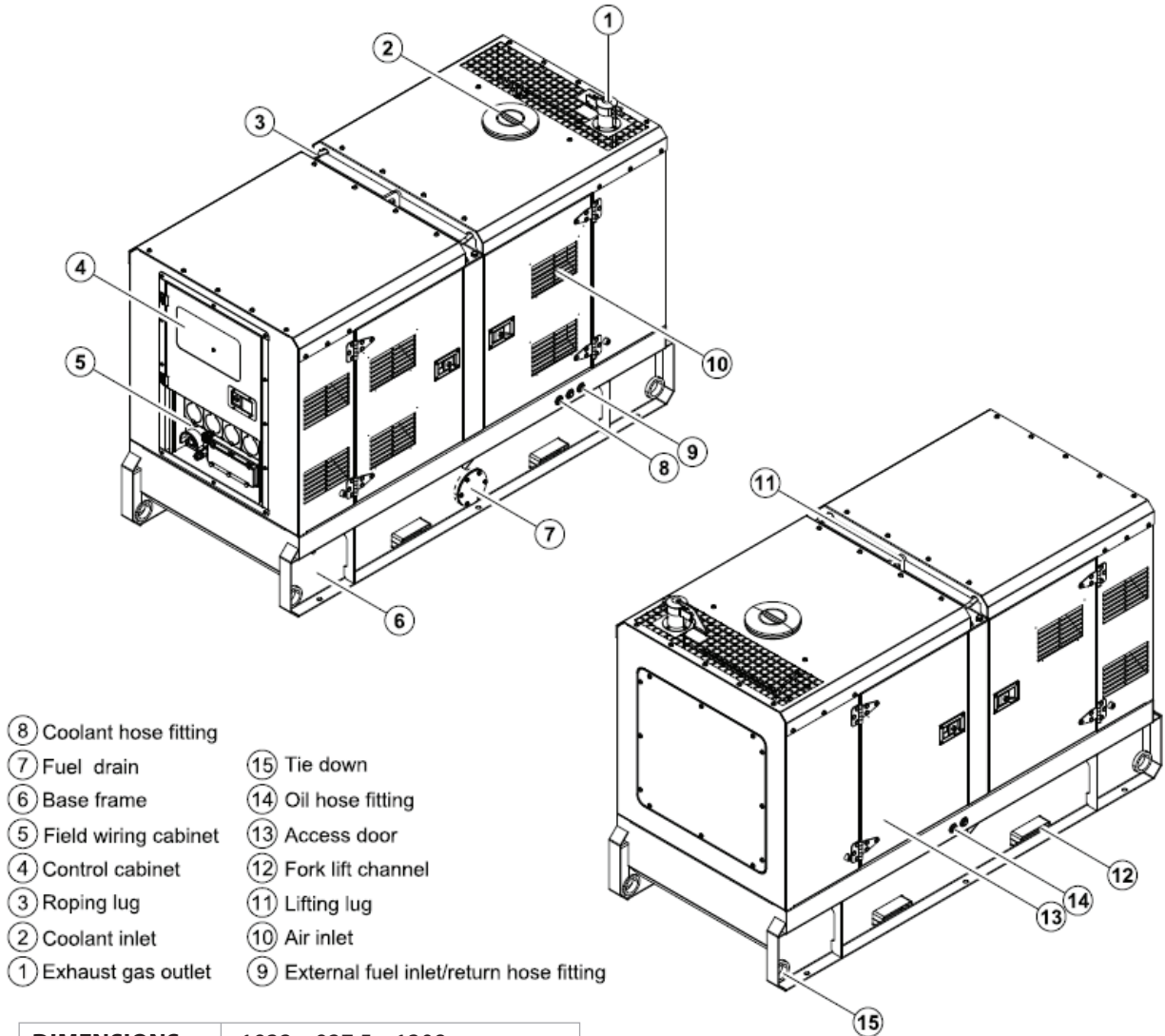

- ⑧ Coolant hose fitting
- ⑦ Fuel drain
- ⑥ Base frame
- ⑤ Field wiring cabinet
- ④ Control cabinet
- ③ Roping lug
- ② Coolant inlet
- ① Exhaust gas outlet
- ⑮ Tie down
- ⑭ Oil hose fitting
- ⑬ Access door
- ⑫ Fork lift channel
- ⑪ Lifting lug
- ⑩ Air inlet
- ⑨ External fuel inlet/return hose fitting

<b>DIMENSIONS</b>	1932 x 927.5 x 1308mm
<b>DRY WEIGHT</b>	691 KG

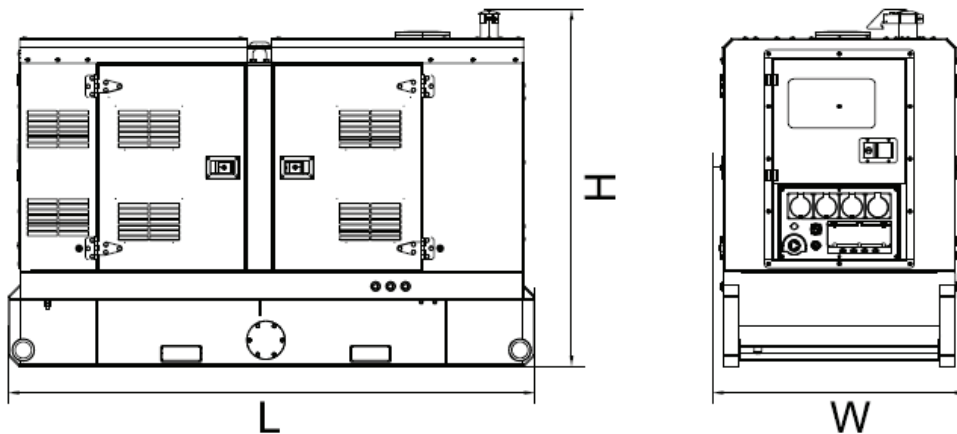

## E. CONTROL SYSTEM

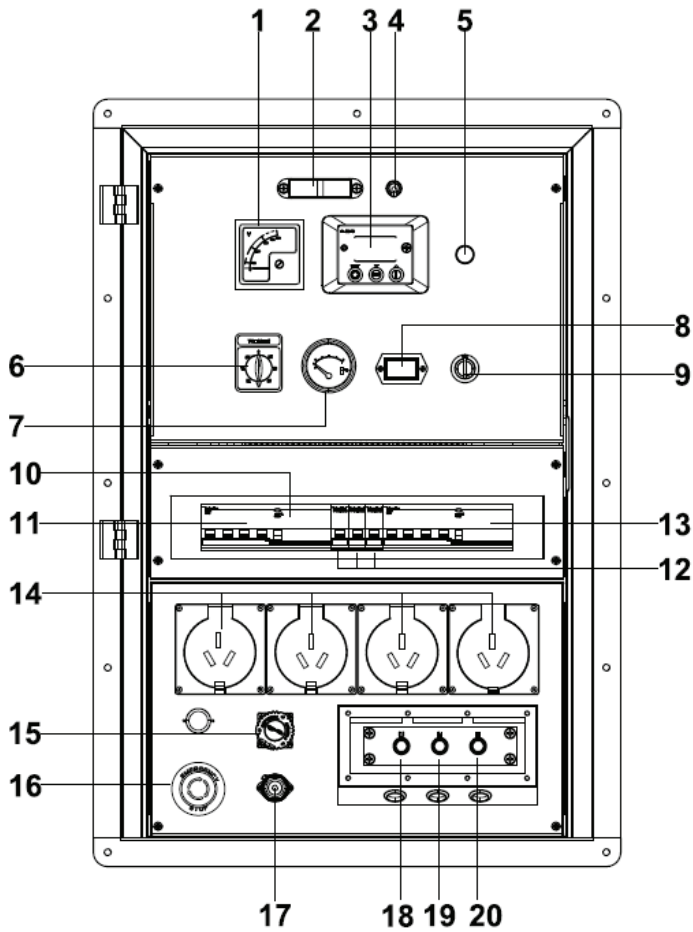

**Control & field wiring cabinet**

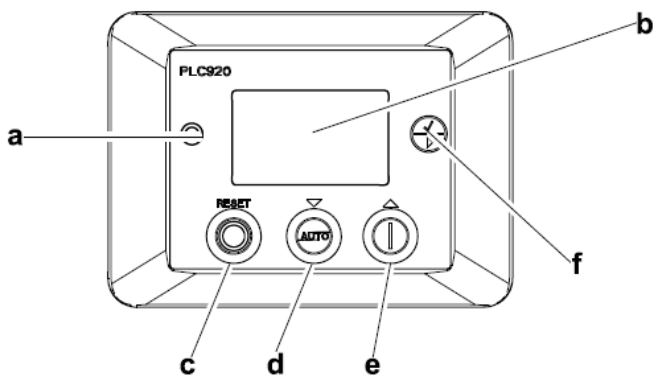

**Control module**

Ref.	Description
1	Voltage Meter
2	Control Cabinet Lamp
3	Control Module
4	Control Cabinet Lamp Switch
5	Charge Indicator
6	Voltmeter Change-over Switch
7	Fuel Level Meter
8	Time Counter
9	Key Switch
10	RCD.
11	Circuit breaker of 3-Phase convenience receptacle
12	Circuit breakers of 1-Phase convenience receptacle
13	Main Circuit Breaker
14	4x Single-Phase Convenience Receptacle
15	Remote Control / ATS Communication Connector
16	Emergency Stop Switch
17	Mains Input / Remote Control Communication Connector
18	Live Wire Terminal
19	Neutral Wire Terminal
20	Ground Wire Terminal

Ref.	Description
a.	Alarm Indicator
b.	Main Status Display
c.	Stop / Reset Button: Next Page (Config. Mode Only)
d.	Auto Start Button: Decrease Value / Next Item (Config. Mode Only)
e.	Start Button: Increase Value / Next Item (Config. Mode Only)
f.	Navigation Button: Accept (Config. Mode Only)

1000022518-I2-E

03.2020