

DGPO15K-3

50 Hz @ 1500rpm, 3-phase/5-wiring

15kVA
KUBOTA

DGPO15K-3

1 Standards & Conditions

Design Standards

The designs and the productions are in conformity with:

- Conformance Europeenne (CE)
- ISO8528-5:2005
- AS 3000-2018
- AS 3010-2017

Environmental Operating Conditions

- Installation place: Outdoors or indoors (well ventilated).
- Ambient temperature: -25°C to 50°C. The coolant heater is needed when the temperature is below 5°C
- Humidity: Less than 90%.
- Altitude: Below one thousand (1000) meters above sea level.

Factory Inspection

- Inspection items.
- Protection devices working test.
- Starting ability in normal temperature.
- 50% rated power load moment capability.
- Voltage deviation and speed variation: 0%, 25%, 50%, 75%, 100%, 110% Load.

Painting Process

- Painting process specifications and colors are based on the manufacturer's standard.
- The customer could also choose the color which the manufacturer offers.

2 General Features

- Kubota engine D1703-BG
- Close coupled to LSA alternator LSA40S3
- Microprocessor control module PLC-920
- SCHNEIDER main circuit breaker: 32A
- Rotate speed governor: Mechanical governor
- Excitation system: Self excited, SHUNT
- A.V.R model: R220
- Key switch
- Emergency stop switch
- ATS (automatic transfer switch) receptacle

- Remote run connector
- 1x12V/60AH sealed for life maintenance free battery
- Lockable battery isolator switch
- Powder coated canopy
- 50°C radiator
- Steel base frame
- Vibration isolators between the engine/alternator and base frame
- Dry type air filter
- Base fuel tank for 30 hours running
- Drain points for fuel tank
- Operation Manual / Specifications

3 Equipment

General technical data

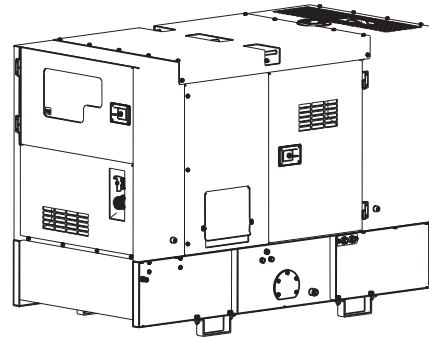

Model.....	QSV15KS-AU
Tank capacity.....	90L
Dry weight.....	723kg
Sound pressure level @ 7m	61.0dBA
Dimensions L×W×H.....	1700x846x1145mm
Standby Power	17kVA/13kW
Prime Power	15kVA/12kW

Voltage	380V	400V	415V	440V	
Ampere	22.8A	21.7A	20.9A	19.7A	
Genset Fuel Consumption					
Frequency/Load	25%	50%	75%	100%	110%
50Hz (L/h)	N/A	2.0	3.0	3.9	4.3

15kVA
KUBOTA

DGP015K-3

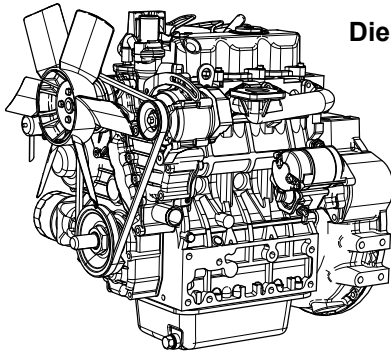

Diesel engine

Engine Manufacturer/Brand.....	KUBOTA
Engine Model.....	D1703-BG
Dimensions L×W×H.....	608.4×548.3×642.8mm
Dry Weigh (approx.)	148kg
Number of Cylinders.....	3
Bore.....	87mm
Stroke.....	92.4mm
Displacement.....	1.647L
Compression Ratio.....	23
Type of Injection	Direct injection
Intake System.....	Natural aspirated
Intake Resistance.....	1.96kPa
Cooling System	Water cooled
Fan	Pusher
Battery Voltage.....	12V
Type of Fuel.....	No.2-D(ASTMD975)
Type of Oil	Class CF lubricating oil
Oil Capacity.....	7.6L
Type of Coolant	Glycol mixture
Coolant Capacity.....	7.1L
Back Pressure.....	≤7.07kPa
Standby Power.....	15.1kW
Prime Power.....	12.8kW
Fuel Consumption(100%load).....	3.9L/h

Alternator

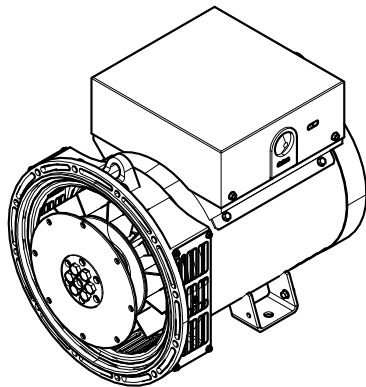

Alternator Manufacturer/Brand.....	Leroy Somer
Alternator Model.....	LA40S3
Exciter.....	Brushless
Cooling Fan	Cast alloy aluminum
Windings.....	100% copper
Insulation Class	H
Winding Pitch.....	2/3
Terminals	12
Drip Proof	IP23
Altitude.....	≤1000m
Overspeed.....	2250rpm
Air Flow.....	N/A
Voltage Regulation	±1.0%
Total Harmonic TGH / THCat no load < 1.5 % - on load < 5%	
Telephone Interference.....	THF<2%;TIF<50

PLC-920 Control System

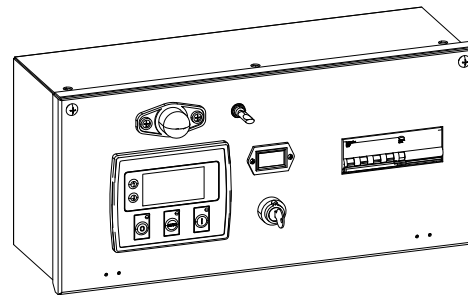

PLC-920 is an advanced control module based on microprocessor designed to control the engine via push buttons on the front panel. The module is used to start and stop the engine and indicate fault conditions, automatically shutting down the engine and giving a true first up fault condition of an engine failure.

Standard Control Function

- Manual Engine Control Module
- Low Oil Pressure
- High Engine Temperature
- Auxiliary Shutdown
- Overspeed Protection
- Protection hold-off timer
- Charge Failure warning

15kVA KUBOTA

DGP015K-3

4 Overall Dimensions

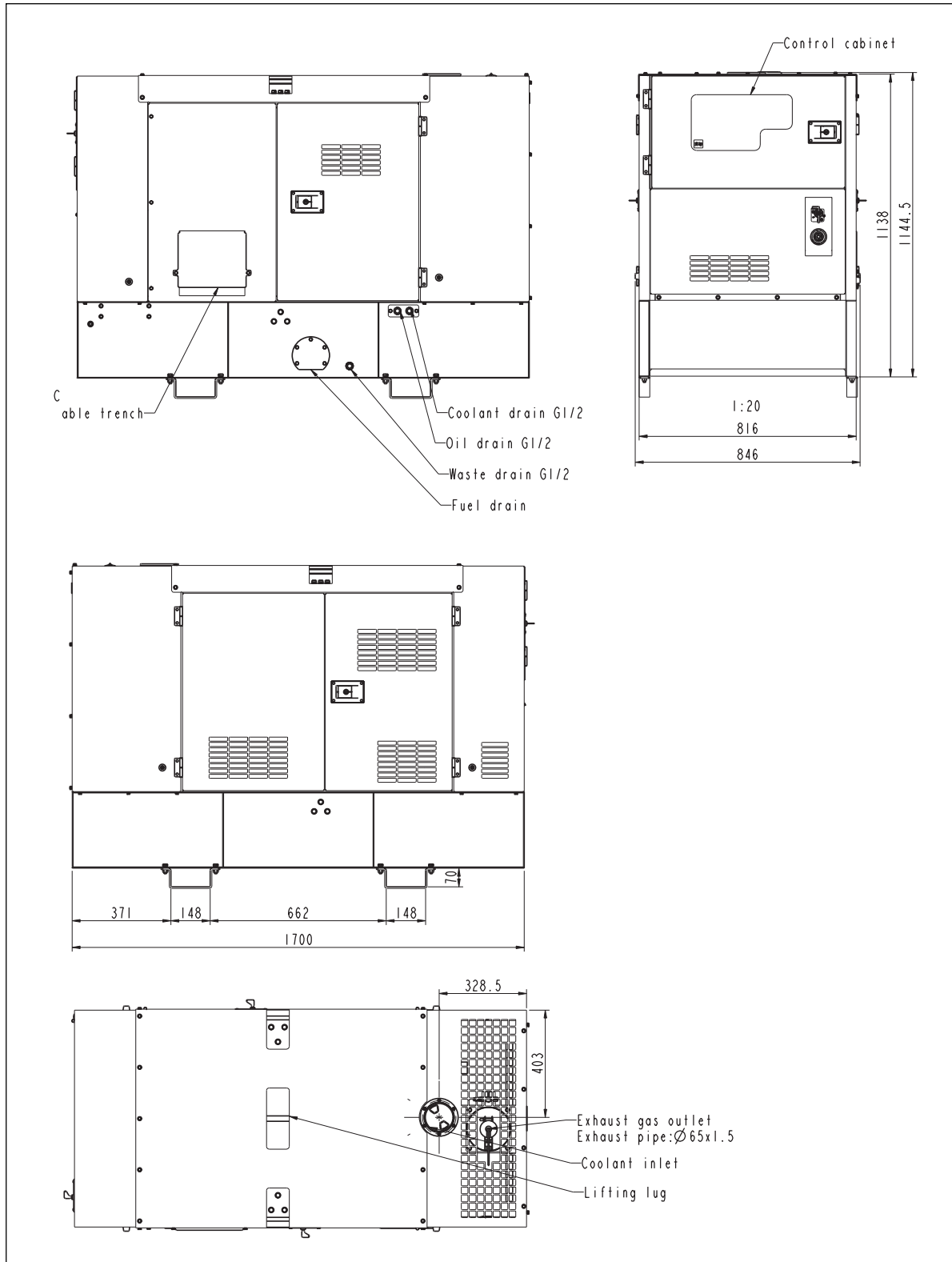

5 Control System

